

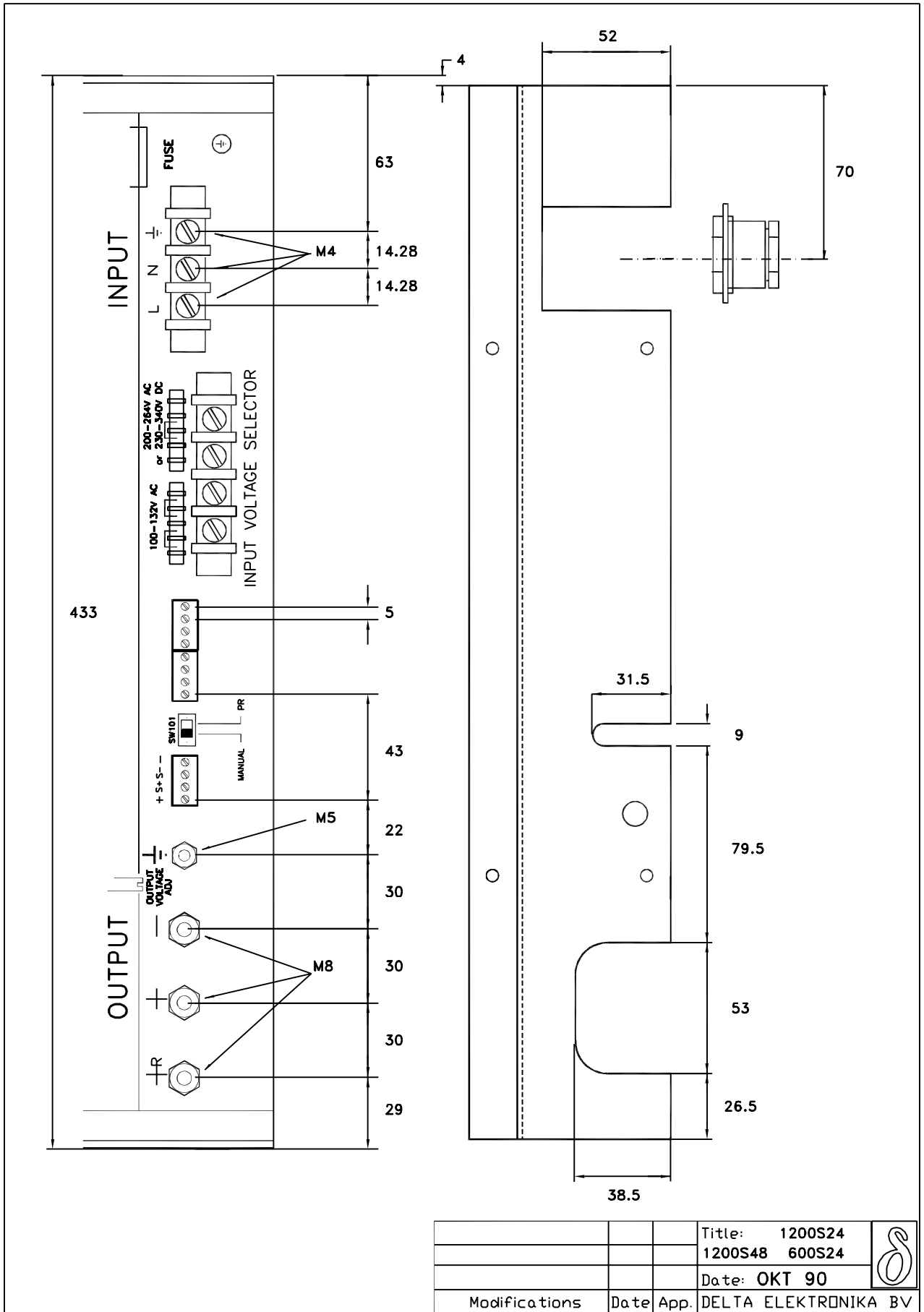

1200 S 24



			Title: 1200S24	
			1200S48 600S24	
			Date: OKT 90	
Modifications	Date	App.	DELTA ELEKTRONIKA BV	

Warning

Before opening the enclosure disconnect the unit from the line voltage and wait three minutes to give the electrolytic capacitors time to discharge.

Also be careful with the low voltage high current output because it can cause harm when a ring or wrist watch, attached to a person, shorts the output terminals.

Also a high current can vaporise metallic objects such as screwdrivers and the molten metal can be sprayed on people.

Installation and operation

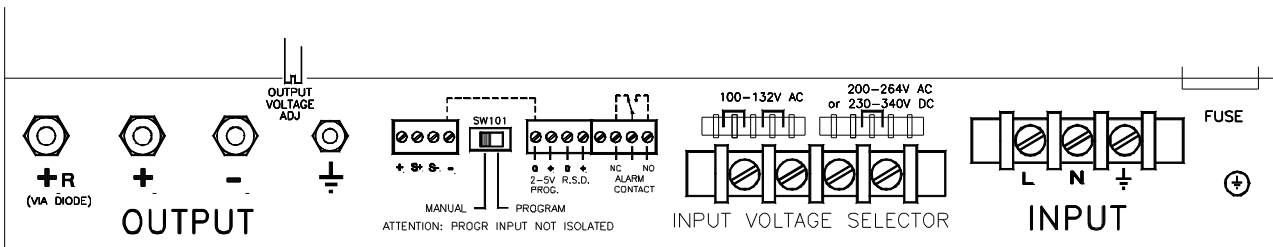

Input voltage selector

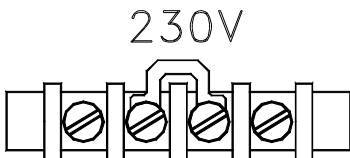

The power supply has a wide input voltage range. With the jumper in the 230V position it can be used at any line voltage between 200 and 264V AC 48/62 Hz or 230 and 340V DC. Put fuse 15A in fuse holder.

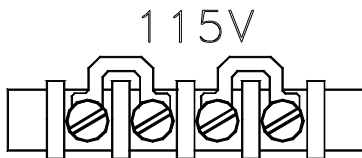

With the two jumpers in the 115V position it can be used at any line voltage between 100 and 132V AC 48/62 Hz. A DC input cannot be used with the jumpers in this position since the input circuit is connected as a voltage doubler. Put fuse 25A in fuse holder.

Sense block

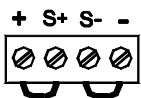

For normal operation S+ has to be connected to + and S- to -.

Recommended wire

Model	INPUT		OUTPUT	
	230V AC	115V AC		Voltage drop
1200 S 24	2.5 mm ²	4.0 mm ²	16 mm ²	56 mV/m at 50A
1200 S 48	2.5 mm ²	4.0 mm ²	6 mm ²	75 mV/m at 25A

Inrush current

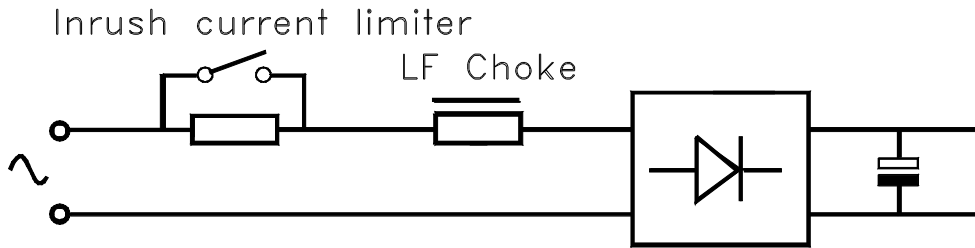

The inrush current limiter limits the inrush current to less than 40A during 5 milliseconds. At turn on the electrolytic capacitors charge through a PTC series resistor of about 40 Ohms. When they are charged sufficiently the series resistor is shorted by a heavy relay contact and the power supply starts operating. In case of a relay failure the PTC becomes high ohmic and limits the current to a safe value.

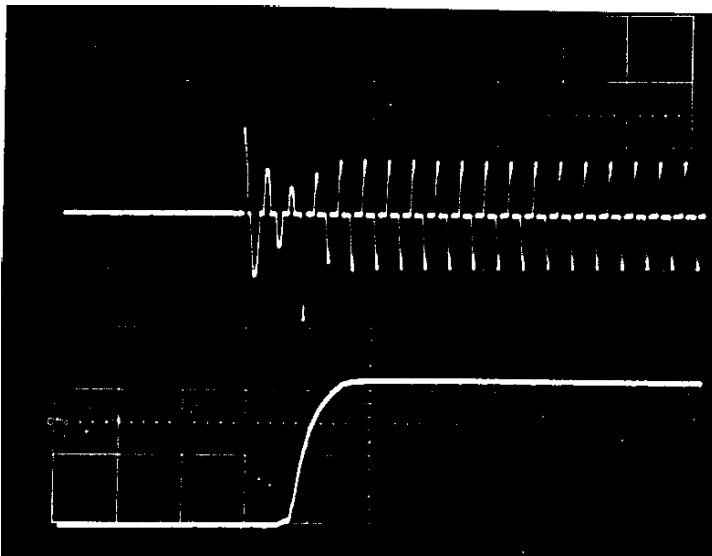

1200 S 24

Input current, vert. 20A/div., hor. 50 mS/div.

Output voltage, vert. 10V/div., hor. 50 mS/div.

Input choke (passive power factor correction)

A switched mode power supply with a bridge rectifier and an electrolytic capacitor at the input takes current only in the peaks of the sine waves. These narrow current peaks can cause distortion in the line voltage.

To minimise this distortion the 1200S has a large low frequency choke with an airgap in series with the input. Such an LF choke is usually not found in power supplies of other manufacturers.

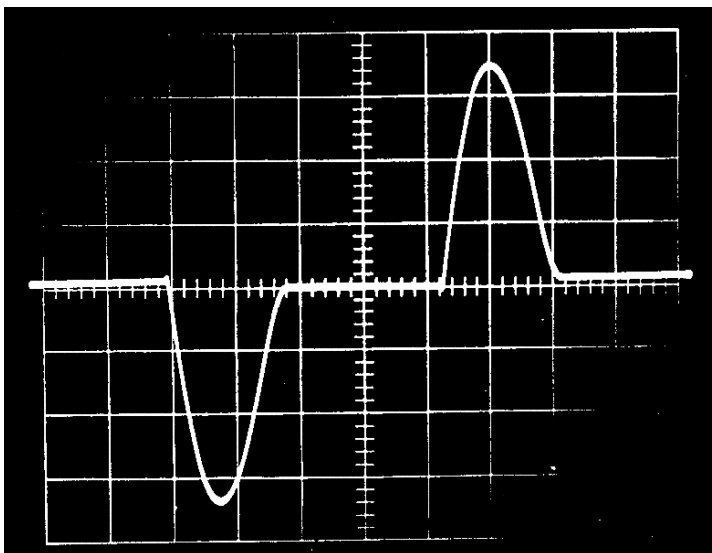

1200 S 24

Input current at 1200 watts load

Vertical scale: 5A/div.
Horizontal scale: 2 mS/div.

Vertical mounting

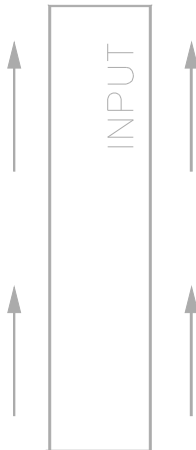

For convection cooling the ideal way of mounting is vertically. For the best internal heat distribution it is recommended to keep the input block at the upper side.

The power supply is so constructed that the heat generated in the semiconductors and transformer flows through a thick aluminium

profile to both covers which act as heat sinks. So it is important that the air can flow freely vertically along both sides. This design with natural convection cooling was chosen to avoid the use of a blower which has disadvantages like noise, dust filters, wear and tear.

At 1200W output and 89% efficiency the total heat dissipation is $1200W/0.89 - 1200W = 148$ watts.

For vertical mounting two types of brackets are available H88 and H114.

Horizontal mounting

Horizontal mounting is also possible, on the condition that the max. ambient temperature does not exceed 40 °C at full load (instead 50 °C when mounted vertically). The current limit switch can be put on 'LO' to limit the max. output to 1100W.

When used in a 19" rack keep sufficient space around the unit for cooling. If more power supplies are mounted above each other the use of forced air to cool is recommended.

For 19" rack mounting brackets H88 with a handle are available.

Remote sensing



For most applications remote sensing is not necessary. However, if the voltage at the load has to be kept very constant (within millivolts) and the voltage drop across the load leads is large, remote sensing is useful.

With remote sensing the voltage is kept constant across the load instead of at the output terminals of the power supply.

The maximum sense range per load lead is 3V. However the voltage across the output terminals, which is the sum of the voltage across load plus leads, cannot exceed 30V (60V 1200 S 48). The two load leads have to be kept closely parallel to minimise the inductance. If there is a capacitor at the load it can together with the lead inductance cause oscillations.

This can be stopped by an electrolytic capacitor of 12000 μ F at the load. Also the sense leads have to be kept close together to minimise pick up of noise.

Parallel operation

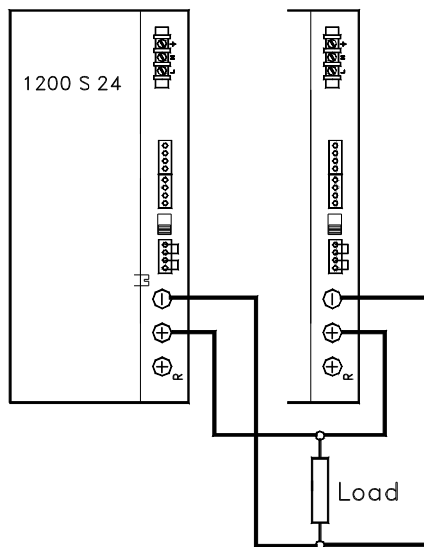

To obtain higher current two or more units can be used in parallel. Before connecting them in parallel first adjust each output to the same voltage. The current limit switch of the 1200S models has to be put on 'LO' to limit the maximum output per unit to about 1100 watts.

Redundant parallel operation

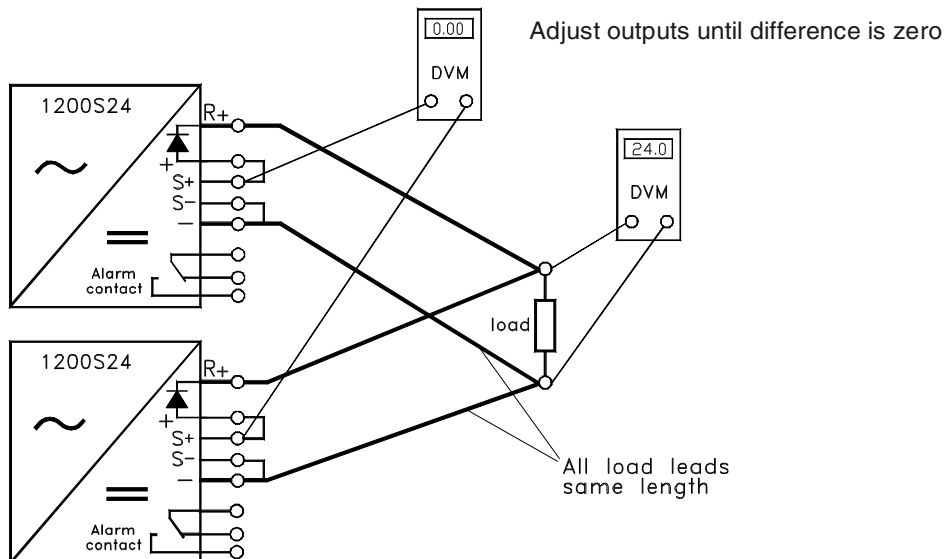

For redundant operation the 1200 S units have a built in series diode and an undervoltage alarm contact. This contact can be used as normally open or as normally closed.

The current limit of the 1200 S 24 and 1200 S 48 is factory adjusted slightly above 100%. For parallel operation the current limit can be reduced to about 90% by putting the current limit switch at the front panel at low.

To get a reasonable current sharing the output voltages of the two or more units have to be adjusted to the same voltage.

An easy way is to measure the voltage difference at a low range of a multimeter and adjust this to zero. After careful adjustment the current sharing is usually within 10%.

It is also important that all the load leads to the summing points have the same resistance (same length).

Parallel operation with external voltage control with one potentiometer

The output voltage of two or more units can be controlled by one external potentiometer. Before connecting them in parallel first calibrate the programming input sensitivity of each power supply. Put 5V from an external source at the progr. input and turn the internal voltage control potentiometer until the output voltage is 30V. After this calibration the power supplies can be connected as drawn. The link between S- and - has to be removed from all units. Do not remove the link between S+ and +. Many units can be operated in parallel to be used as one big power supply.

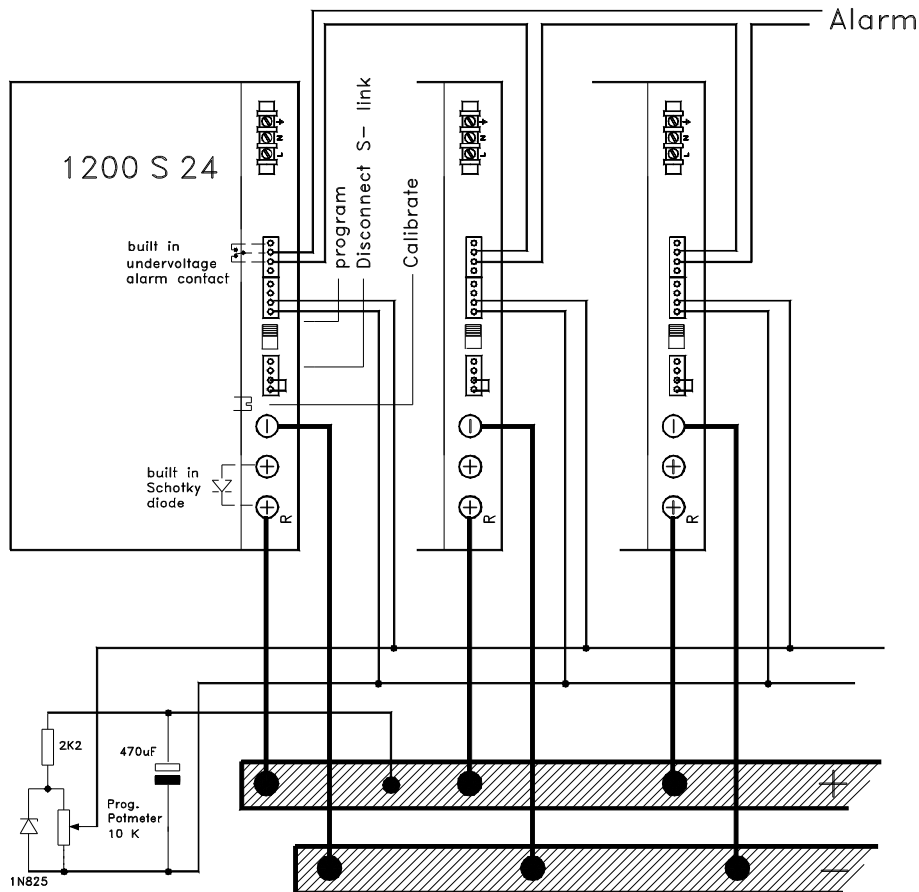

Remote voltage control

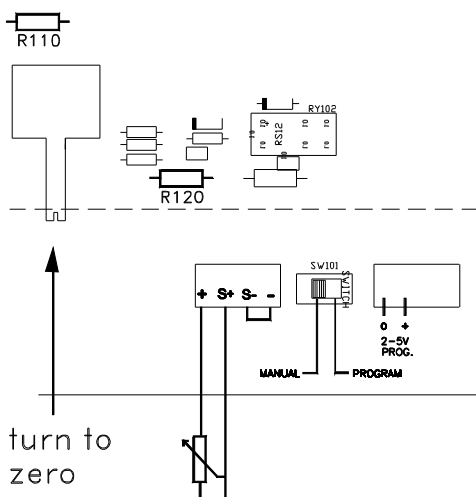

Voltage adjustment with an external potentiometer of 10 kOhms is possible if R 120 and R 110 are removed. The potentiometer can be connected as a variable resistor between S+ and + at the sense block. The internal potmeter has to be turned to zero.

This method of voltage control by external potentiometer cannot be used with parallel operation.

Remote programming

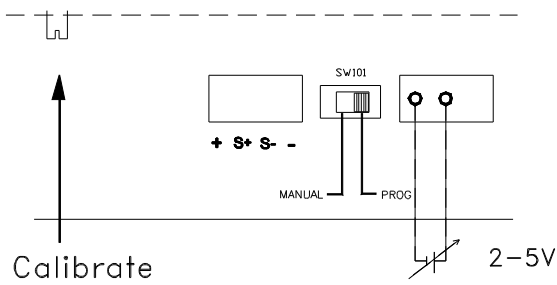

Attention: The programming input is not isolated. The zero of the progr. input is connected to minus output. When the small switch near the programming input is put on PROG (program) the output voltage of the power supply can be programmed by an analog voltage of 2 to 5V, corresponding with 12 to 30V output. For 1200 S 48 this is 24 to 60V . The programming speed is 100 milliseconds for a change from 12 to 30V at full load. The programming range 2-5V can be calibrated with the 10-turn voltage adjustment potentiometer. To calibrate put 5V at the programming input and turn the voltage adjustment potentiometer till the output voltage is 30V (60V).

1200 S 24

Output 12 - 30V 40A
 Vert.: 5V / div.
 Hor.: 20 mS / div.

Programming voltage 2 - 5V
 Vert.: 2V / div.
 Hor.: 20 mS / div.

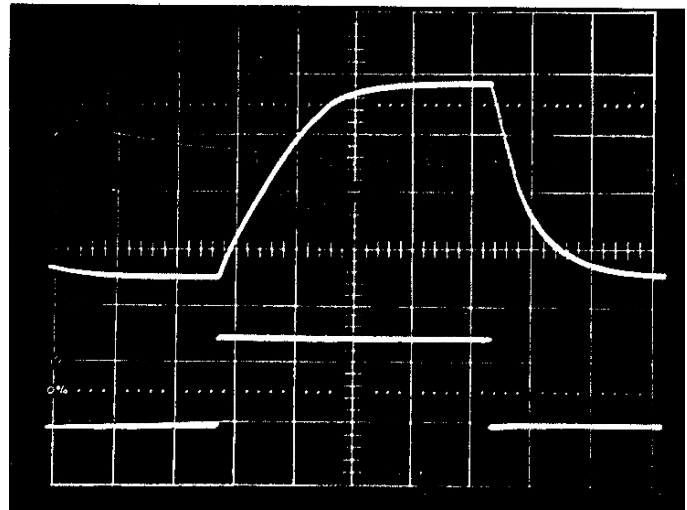

Remote shut down

Remote shut down of the output voltage is possible by 5V (3-12V) at the RSD input. The RSD input is low ohmic (500Ω). The RSD input is isolated from the output by an optocoupler (isolation 1000V).

Programming

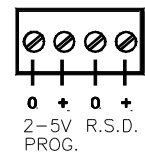

Current limit

The current limit is fixed and has a more or less constant power characteristic. The 1200S models have a switch, accessible through a hole in the front panel, which can be put on HI or LO by a screw driver. On LO the maximum output power is limited to about 1100 watts.

Insulation

For safety, the insulation of the separating components (transformers and optocouplers) between input and output are tested at 3750 Vrms during 1 minute. This is tested before assembling. The 3750 Vrms cannot be tested afterwards on the assembled unit because the insulation between the components on the input side to the case (like the bridge rectifier) is specified at 2500 Vrms. Since the insulation output - case is low (only 500 VDC) the insulation of the primary components to case will break down when 3750 Vrms is applied between input and output (2500 Vrms + 500 VDC < 3750 Vrms). The Y-capacitors of the RFI filter make it difficult to test with 2500V AC between input and case. It is more practical to test with 1.4 x 2500 = 3500V DC.

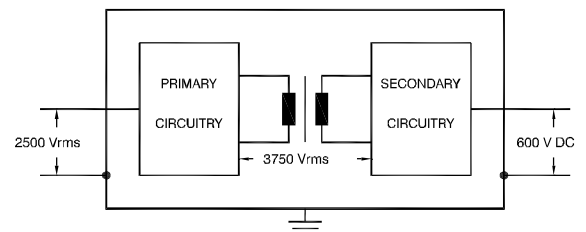

Dividing the load in sections, each with its own fuse

In general it is not recommended to use a fuse in the DC output of an electronic regulated power supply. The electronic current limit is very fast compared to fuses and it is sharply defined so there is not enough time and not enough overcurrent to blow a fuse.

This makes it difficult to divide the load in sections each with its own fuse.

Even for very fast fuses the time to blow is still in the order of 50 seconds at twice the nominal current ($2 I_N$). At $4 I_N$ this is already much better and can be in the order of 20 milliseconds.

However compared with the electronic current limit this is still too long and all sections will see a dip in the 24V. The best results we found with the circuit breakers S 280 Z of ABB. They are the fastest.

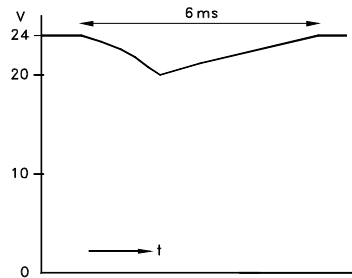
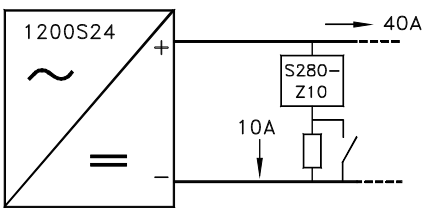
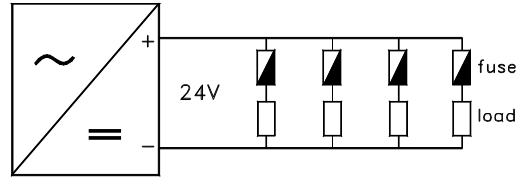

In the above situation there is still a considerable voltage dip during 6 ms. This can be improved by one or more large electrolytic capacitors which can supply a high current peak for a fast action of a fuse or a circuit breaker.

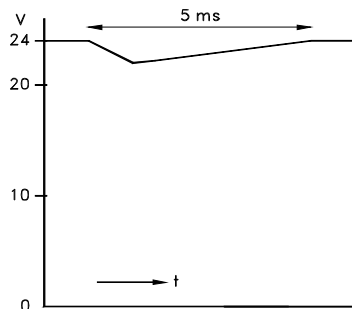
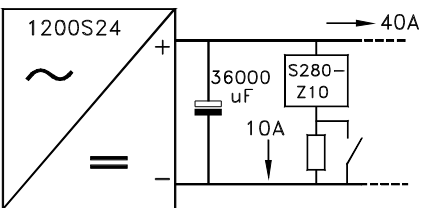

1200 S 24 with 36 000 μF parallel

A disadvantage of the large electrolytic capacitor can be that the current limit is no longer fast.

The inductance of long leads (several meters) between the power supply and the load can cause very large voltage dips when a fuse is blown. This can be avoided by connecting the electrolytic capacitor close to the load.

Schulz-Electronic GmbH
 Dr.-Rudolf-Eberle-Straße 2
 D-76534 Baden-Baden
 Fon +49.7223.9636.0
 Fax +49.7223.9636.90
 vertrieb@schulz-electronic.de
 www.schulz-electronic.de

