

PSE250

DC-DC Converter



PSE250-series 150 to 250W

Input / Output

- Optimized input voltage ranges.
- Single outputs from 12 to 48V.
- Reverse input voltage protection.

Operation

- High efficiency. >88%.
- Operating temperature range -25 to +70°C.
- Fully encapsulated, meets IP30 as standard.
- Convection cooled.
- Low voltage alarm, with logic signal.

Features

- Conformally coating, tropic.
- Under voltage logic alarm.
- Accessible on front panel:
 - Output voltage adjustment.
 - Output voltage measurement.
 - Output OK status green LED.

EMC

- EN61000-6-3, Emission.
- EN61000-6-2, Immunity.
- EN/IEC61000-4-4, 4kV.
- EN/IEC61000-4-5 level 2&3.

Input and output ratings

Standard input ranges			
Nominal inputs	Input range	Stop level	Code
24 Vd.c.	20 to 32V	<16.8Vd.c.	24
48 Vd.c.	38 to 60V	<33.6Vd.c.	48
110 - 125 Vd.c.	88 to 150V	<77Vd.c.	110
220 Vd.c.	187 to 270V	<154Vd.c.	220

DC inputs mobile		
Uin 0.1s- S2	Continous range	Code
14.4 - 33.6Vd.c.	16.8 - 30Vd.c.	24T
21.6 - 50.4Vd.c.	25.2 - 45Vd.c.	36T
28.8 - 67.2Vd.c.	33.6 - 60Vd.c.	48T
43.2 - 100.8Vd.c.	50.4 - 90Vd.c.	72T
66 - 154Vd.c.	77 - 137.5Vd.c.	110T

The total output power can be derated on a T-range compared to the above output rating table.

Output		
Voltage	Current	Power
12V	12.5A	150W
13.2V	11.3A	150W
15V	10.0A	150W
24V	8.3 - 10.4A	200 - 250W
48V	4.1 - 5.2A	200 - 250W

Other input and outputs combination on demand.

Input range:

The range we guarantee full output performance, $U_{out} +10%$ $I_{out} +5%$.

Stop level:

The converter works down to the stop level.

The output voltage might decrease to approx -10% of nominal output at the stop level at the stop level.

Output ratings and type code

Output			Input				Case
Voltage	Current	Power	20 - 32V	41 - 60V	93 - 150V	185 - 300V	
12V	12.5A	150W	PSE150 24/12	PSE150 48/12	PSE150 110/12	PSE150 220/12	8TE
13.2V	11.3A	150W	PSE150 24/13.2	PSE150 48/13.2	PSE150 110/13.2	PSE150 220/13.2	8TE
15V	10.0A	150W	PSE150 24/15	PSE150 48/15	PSE150 110/15	PSE150 220/15	8TE
24V	8.3A	200W	PSE200 24/24	PSE200 48/24	PSE200 110/24	PSE200 220/24	8TE
24V	10.4A	250W	PSE250 24/24	PSE250 48/24	PSE250 110/24	PSE250 220/24	10TE
48V	4.1A	200W	PSE200 24/48	PSE200 48/48	PSE200 110/48	PSE200 220/48	8TE
48V	5.2A	250W	PSE250 24/48	PSE250 48/48	PSE250 110/48	PSE250 220/48	10TE

How to read our product code:

Example **PSE250 48/24**

PSE250 = Family code

48 = input voltage code

24 = Output voltage 24V

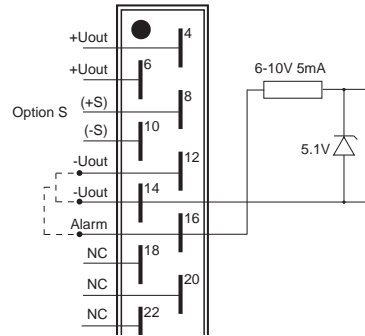

Figure 2. 5 V logic alarm signal

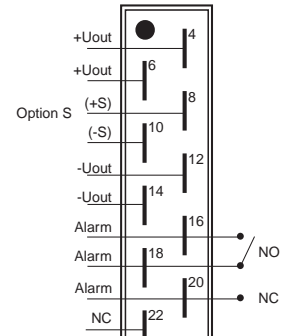

Figure 3. Alarm relay output Option -B

Features

Conformal coating

PSE250 is conformal coated to withstand noncondensing tropical environment.

Under voltage logic alarm

On DC-inputs a built in logic alarm changes to alarm state if the converter voltage drops below -10% of nominal output. The alarm circuit also controls the DC OK LED.

The DC OK or POWER GOOD signal is logic 1. The drive voltage is 8 to 10 V, 5 mA = logic 1. See also Figure 2.

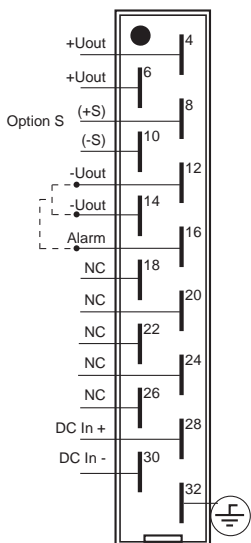

Figure 1. Pin-out DIN41612, H15

Optional Features

Overvoltage protection OVP, option A

The output filter is limited to 15% over nominal output voltage. A thyristor short-circuits the output.

Undervoltage alarm with relay, option B

The logic alarm output is replaced with a relay with selectable alarm logic NO or NC.

Alarm = No input or low output <-10% of nominal output, see figure 3.

The relay is rated 30V 0.5A (a.c. & d.c.).

Built in series diode, option C (Derating 20%)

A series diode on the output, which is mounted inside the case. Use this option when output is connected in parallel with other power supplies to achieve redundancy. The output power is derated. It is model depend, contact factory.

Remote sense, option S

The voltage sensing can be put at the load to compensate for voltage drop.

Inrush current limit with NTC, option H

Only for C-input code. Reduce the inrush current during start up. The input voltage range will be affected.

2.5 kVa.c. isolation Input/case, option E1

On 24, 36 and 48 inputs.

The emission level increase to level A.

2.5 kVa.c. isolation Output/case, option E2

The emission level increase to level A.

Train input

Input voltage range according to train standard EN50155 and IEC60571. See Mobile Inputs.

General data / input data

Design topology	Push-Pull
Switching frequency	100 kHz
Emission / immunity	See page 4
Safety EN/IEC60950	Class I
Max accepted input ripple 50 - 400Hz	2% of nom. Voltage
Reverse input voltage protection	Parallel diode
Inrush current limit with NTC	Optional

- Higher ripple affects the input, contact factory

Output data

Source regulation	0.2%
Load regulation (0-100% load)	0.2%
Transient recovery time for a load step of 10% to 100% voltage deviation	<2ms 3%
Output ripple (100kHz)	Typ. 10mVp-p ²
Input ripple attenuation on output 50 to 400Hz	150:1
Emission / Immunity	See page 4
Temperature coefficient	0.02% /°C
Min output adjustment range adjustable with a 15 turn potentiometer	90% to 110%
Current limit, rectangular.	105%
Remote sense	Option S
Soft start	Yes
Start-up time	1s
Hold-up time, contact factory	2-10ms
Efficiency ³	>88%
Operating temperature range at 100% load. Conduction cooling with outputs >10 V	-25 to +70°C
Operating temperature range at 100% load.	-25 to +55°C
Storage temperature range	-40 to +85°C

- Output ripple might increase to 0.5% RMS of V_{out} , when EN/IEC61000-4-3, 10V/m test is applied
- Lowest efficiency measured within the whole input voltage range at 100% load.

Mechanical Options

Front panel for Euroformat

8TE 3HE on PSE150 and PSE200

10TE 3HE on PSE250 See figure 6.

Wall mounting panels -N, see figure 7 & 8

Including connector holder.

H15 Screw type female-H15-S

H15 FastOn 6.3mm female -H15-T

DIN rail TS35 clips -Q

Mechanical drawing

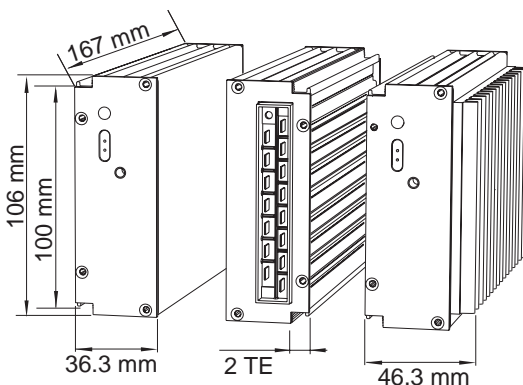

Figure 4. Dimensions.
Weight: 0.85 kg.

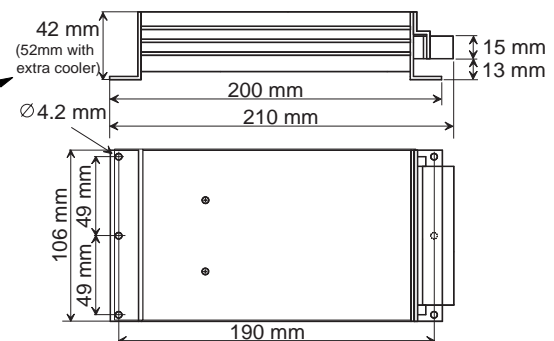
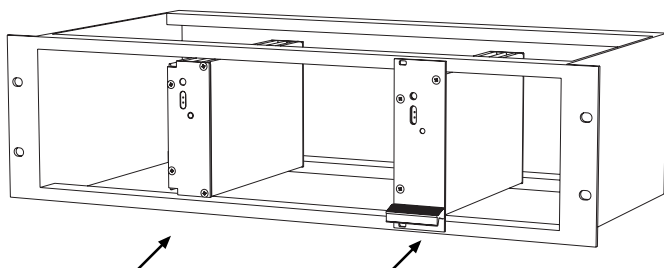

Figure 5. Optional extra
cooler version
Weight: 1.05 kg

Figure 7. Dimensions with option N, wall mounting
Weight: 0.91 kg with extra cooler 1.11 kg

PSE wall mounted.
Using PSE wall mounting
kit, option N with connector
holder. Female H15
connector with screw or tab
connectors (Optional).

PSE DIN-rail mounted.
Using PSE wall mounting kit, option N
with addition of 2x DIN-rail clips
Option Q



PSE mounted in a 19" Sub-rack. Standard unit. PSE mounted in a 19" Sub-rack with L panel 8TE & 10TE (Optional)

Figure 6. 3HE 19" sub rack mounting.

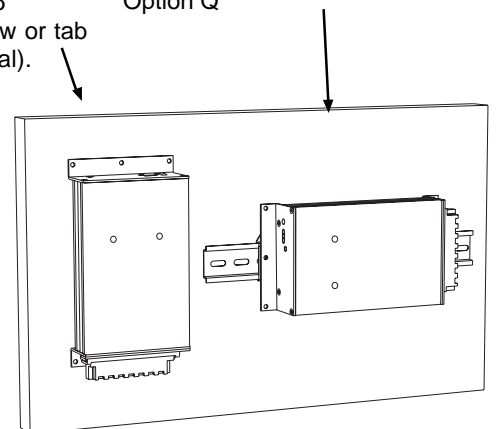

Figure 8. Wall mounting
Option -N.

PSE250 meets the requirements defined by CE mark as apparatus.

PSE250 meets requirements of EMC directive and low voltage directive (LVD).

Thus a PSE250 can be used as free standing unit or in installations as well as systems designed according to "The modular approach". PSE250 can be used in installation without further EMC tests, if our installation instructions are followed. Please note that product standards can demand different levels or other basic standard tests. We test according to levels below. For higher levels or other tests, contact factory.

Isolation testable levels	Test voltage
Input / output:	2.5kVa.c. / 4kVd.c.
Input / Case	2.5kVa.c. / 4kVd.c.
Output / Case all outputs	2kVd.c.
Isolation, not testable level	Safety Isolation
Transformer isolation In/Out:	4 kVa.c./8mm

We use the product standard Low voltage power supplies, DC outputs EN/IEC61204-3 and the generic EMC standards:
 EN/IEC61000-6-2 (Immunity)
 EN/IEC61000-6-3 (Emission)

EMC

EMC-standards	EMC-performance		Remarks
Emission standards	Input	Output	
EN55011/EN55022 (0.15-30MHz)	Level B	Level B	
EN55011/EN55022 (30-1000MHz)	Level B		Enclosure test
Immunity standards	IEC/EN61000-6-2		
EN/IEC61000-4-2	8 kV/15 kV		Contact / air, Enclosure test
EN/IEC61000-4-3	10 V/m AM-Modulated ²		Output ripple can increase to 0.5% of Vout Enclosure test
EN/IEC61000-4-4	4 kV	4 kV	
EN/IEC61000-4-5, Input code <60	0.5kV / 1 kV	0.5kV / 1 kV	Line-line 2Ω / Line-case 12Ω
EN/IEC61000-4-5, Input code >60 ¹	1kV / 2 kV	0.5kV / 1 kV	
EN50155 Figure 4, 1.8kV 1.5/50μs	Yes		Line-line 100 Ω
EN/IEC61000-4-6	10 V _{RMS}	10 V _{RMS}	AM-Modulated
EN/IEC61000-4-8	Not sensitive		Enclosure test
EN/IEC61000-4-10	Not sensitive		Enclosure test

- Higher level 2kV / 4kV with external filters, contact factory.
- Level increased to 20V/m on T-Inputs

Contact

For updates on this datasheet we refer to www.polyamp.com
 Specifications subject to change without notice.



Switch Craft S.A.
 Ruel bel Air 63
 CH-2300 La Chaux-de-Fonds Switzerland
 Telephone: +41 32 96 78800
 Telefax: +41 32 96 78809
 E-mail: info@polyamp.se

Distributor