

PSE100

DC-DC Converter



PSE100-series DC/DC 100W

Input / Output

- Wide input voltage ranges.
- Input ranges from 10 to 270V.
- Single outputs from 5 to 48 Vd.c.
- Reverse input voltage protection.

Operation

- High efficiency.
- Operating temperature range -25 to +70°C.
- Fully encapsulated, meets IP30 as standard.
- Convection cooled.
- Low voltage alarm, with logic signal.

Features

- Under voltage logic alarm.
- Conformally coating, tropic.
- Accesible on front panel.
 - Output voltage adjustment.
 - Output voltage measurement.
 - Output OK status green LED.

EMC

- EN61000-6-3, Emission.
- EN61000-6-2, Immunity.
- EN/IEC61000-4-4, 4kV.
- EN/IEC61000-4-5 level 2&3.

Input and output ratings

Nominal inputs	Input range	Code
12, 24 Vd.c.	10 to 30V	A
24, 28, 36, 48, 60 Vd.c.	20 to 72V	B
110, 127 Vd.c.	50 to 150V	C
110, 127, 220 Vd.c.	90 to 270V	D

Input voltages meeting train standard EN50155/IEC60571, can be made on demand.
For 36V use standard B-input range.
For 110V use standard C-input range.

Output		
Voltage	Current	Power
5V	20.0A	100W
13.2V	7.6A	100W
15V	6.7A	100W
24V	4.2A	100W
48V	2.1A	100W

Output ratings and type code

Output			Input			
Voltage	Current	Power	10 - 30V	20 - 72V	50 - 150V	90 - 270V
5V	20.0A ¹	100W	PSE100A5	PSE100B5	PSE100C5	PSE100D5
13.2V	7.60A	100W	PSE100A13.2	PSE100B13.2	PSE100C13.2	PSE100D13.2
15V	6.70A	100W	PSE100A15	PSE100B15	PSE100C15	PSE100D15
24V	4.20A	100W	PSE100A24	PSE100B24	PSE100C24	PSE100D24
48V	2.10A	100W	PSE100A48	PSE100B48	PSE100C48	PSE100D48

¹⁾-25 to +55°C 100% load, 70°C at 75% load. With extra cooler, see mechanical drawing figure 5, the rating is 100% load @ +70°C

How to read our product code:

Example **PSE100 A24**

PSE100 = Family code

A = Input voltage code A

24 = Output voltage 24V

Features

- **Conformal coating**
PSE100 is conformal coated to withstand noncondensing tropical environment Rh 95%.
- **Under voltage logic alarm**
On DC inputs A built in logic alarm changes to alarm state if converter output voltage drops below -10% of nominal output. The alarm circuit also controls the DC OK LED. The DC OK or POWER GOOD signal is logic 1. The drive voltage is 8 to 10 V, 5mA = logic 1. See also figure 2 & 3

Optional Features

- **Oversvoltage protection OVP, option A**
The output voltage is limited to 15% over nominal output voltage. A thyristor short-circuits the output.
- **Undervoltage alarm with relay, option B**
The logic alarm output is replaced with a relay with selectable alarm logic NO or NC. Alarm = No input or low output <-10% of nominal output. See figure 2. The relay is rated 30V 0.5A (a.c. & d.c.).
- **Built in series diode, option C**
A series diode on the output, which is mounted inside the case. Use this option when output is connected in parallel with other power supplies to achieve redundancy. The output power might be derated. Model dependent, contact factory.
- **Remote sense, option S**
The voltage sensing can be put at the load to compensate for voltage drop. Is a standard feature on 5V output.
- **Inrush current limit with NTC, option H**
Only for C-input code. Reduce the inrush current during start up. The input voltage range will be affected.
- **2.5 kVa.c. isolation input/case, option E1**
On A and B inputs. The emission level increase to level A.
- **2.5 kVa.c. isolation output/case, option E2**
The emission level increase to level A.
- **Train input**
Input voltage range according to train standard EN50155 and IEC60571.
- **8 TE Euro panel, option L**, see figure 6.
- **Wall mounting panels, option N**, see figure 5 and 7. Including connector holder.
- **H15 Screw type female-H15-S.**
- **H15 FastOn 6.3mm female -H15-T.**
- **DIN rail TS35 clips -Q.**

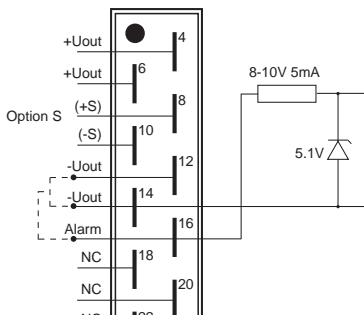

Figure 1. 5 V logic alarm signal

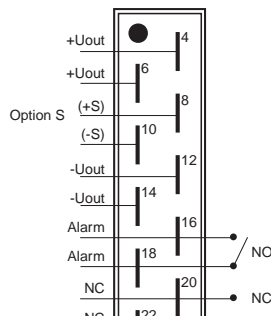

Figure 2. Alarm relay output Option B

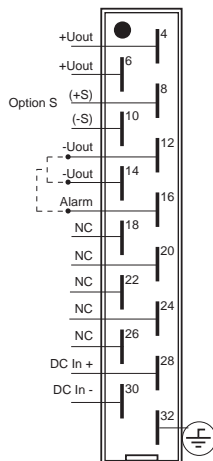

Figure 3. Pin-out DIN41612, H15

General data / input data

Design topology	Push-Pull
Switching frequency	100 kHz
Emission / immunity	See page 4
Safety EN/IEC60950	Class I
Max. accepted input ripple ¹ 50-400Hz	2% of nominal voltage
Power consumption at no load	3 to 5W
Reverse input voltage protection	Parallel diode
Inrush current limit with NTC	D input code
Isolation	see table page 4
Dimensions (D x W x H)	167 x 36.3 x 106
Weight	0.85 kg

1. Higher ripple affects the input, contact factory

Output data

Source regulation	0.2%
Load regulation (0-100% load)	0.2%
Transient recovery time of 10%-90% voltage deviation	<3ms
Output ripple (100kHz)	Typ. 10mVp-p ²
Input ripple attenuation to output (50 to 400 Hz).	150:1
Emission / Immunity	See page 4
Temperature coefficient	0.02% /°C
Min output adjustment range adjustable with a 15 turn potentiometer	90% to 110%
Current limit, rectangular.	105%
Remote sense	Option S
Soft start	Yes
Start-up time	1 s
Hold-up time, contact factory	2-10ms
Efficiency ³	80-88%
Operating temperature range at 100% load. Conduction cooling with outputs >10 V	-25 to +70°C
Operating temperature range at 100% load. Conduction cooling with outputs <10 V	-25 to +55°C
Storage temperature range	-40 to +85°C

- Output ripple might increase to 0.5% RMS of V_{out} , when EN/IEC61000-4-3, 10V/m test is applied
- Lowest efficiency measured within the whole input voltage range at 100% load.

Mechanical drawing

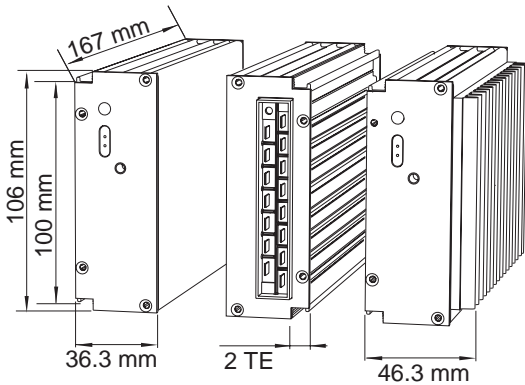

Figure 4. Dimensions.
Weight: 0.85 kg.

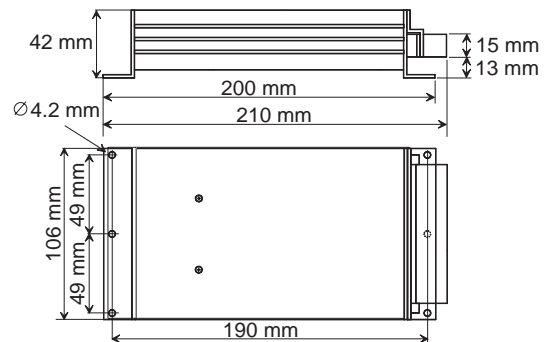
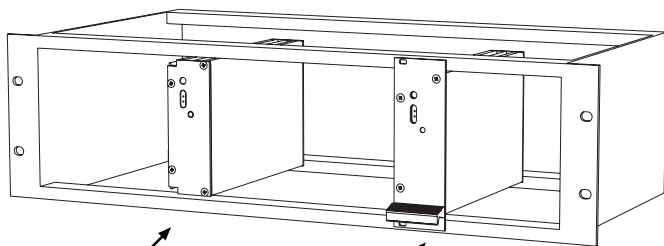

Figure 5. Optional extra cooler version

Figure 6. Dimensions with option N, wall mounting
Weight: 0.91 kg

PSE wall mounted.
Using PSE wall mounting kit, option N with connector holder. Female H15 connector with screw or tab connectors (Optional).

PSE DIN-rail mounted.
Using PSE wall mounting kit with addition of 2x DIN-rail clips (Optional).



PSE mounted in a 19" Sub-rack. Standard unit.
PSE mounted in a 19" Sub-rack with L panel 8TE & 10TE (Optional)

Figure 6. 3HE 19" sub rack mounting.

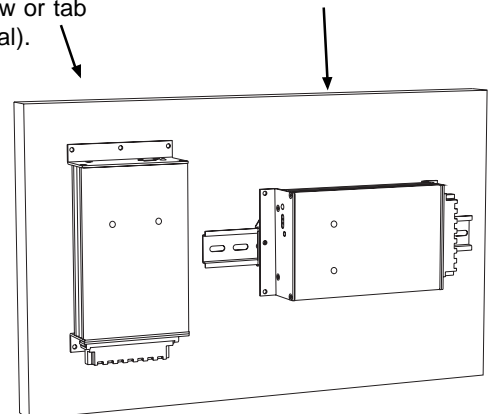

Figure 7. Wall mounting
Option -N.

Safety and EMC



Safety standard IEC60950

PSE100 meets the requirements defined by CE mark as apparatus.

PSE100 meets requirements of EMC directive and low voltage directive (LVD).

Thus a PSE100 can be used as free standing unit or in installations as well as systems designed according to "The modular approach". PSE100 can be used in installation without further EMC tests, if our installation instructions are followed. Please note that product standards can demand different levels or other basic standard tests. We test according to levels below. For higher levels or other tests, contact factory.

Isolation testable levels	Test voltage
Input / output: Input code: A, B	2kVd.c.
Input code: C, D	2.5kVa.c. / 4kVd.c.
Input / Case Input code: A, B	2kVd.c.
Input code: C, D	2.5kVa.c. / 4kVd.c.
Output / Case all outputs	2kVd.c.

We use the product standard Low voltage power supplies, DC outputs EN/IEC61204-3 and the generic EMC standards:
EN/IEC61000-6-2 (Immunity)
EN/IEC61000-6-3 (Emission)

EMC

EMC-standards	EMC-performance		Remarks
Emission standars	Input	Output	
EN55022 (0.15-30MHz)	Level B	Level B	
EN55022 (30-1000MHz)	Level B		Enclosure test
Immunity standards	IEC/EN61000-6-2		
EN/IEC61000-4-2	8 kV/15 kV		Contact / air, Enclosure test
EN/IEC61000-4-3	10 V/m AM-Modulated		Output ripple can increase to 0.5% of Vout Enclosure test
EN/IEC61000-4-3	10 V/m Pulse modulated		Enclosure test
EN50155 Figure 4, 1.8kV 1.5/50µs	Yes		Line-line 100 Ω
EN/IEC61000-4-4	4 kV	4 kV	
EN/IEC61000-4-5, Input code A, B	0.5kV / 1 kV	0.5kV / 1 kV	Line-line 2Ω / Line-case 12Ω
EN/IEC61000-4-5, Input code C ¹ , D ¹	1kV / 2 kV	0.5kV / 1 kV	
EN/IEC61000-4-6	10 V _{RMS}	10 V _{RMS}	AM-Modulated
EN/IEC61000-4-8	Not sensitive		Enclosure test
EN/IEC61000-4-10	Not sensitive		Enclosure test

1 Higher level 2kV / 4kV with external filters, contact factory.

Contact

For updates on this datasheet we refer to www.polyamp.com
Specifications subject to change without notice.



Switch Craft S.A.
Ruel bel Air 63
CH-2300 La Chaux-de-Fonds Switzerland
Telephone: +41 32 96 78800
Telefax: +41 32 96 78809
E-mail: info@polyamp.se

Distributor



SCHULZ-ELECTRONIC GMBH • DR.-RUDOLF-EBERLE-STRASSE 2
D-76534 BADEN-BADEN • TEL. 072 23 - 96 36 30 • FAX. 072 23 - 96 36 90
E-MAIL: VERTRIEB@SCHULZ-ELECTRONIC.DE
INTERNET: WWW.SCHULZ-ELECTRONIC.DE