

PSC240

DC-DC Converter



PSC240-series DC/DC 210-240W

Input / Output

- Optimized input voltage ranges.
- Single outputs from 15 to 110V.
- Reverse input voltage protection.

Operation

- High efficiency.
- Operating temperature range -25 to +70°C with no derating.
- Fully encapsulated, meets IP30 as standard.
- Convection cooled.
- Inhibit /Power Down input.
- Low voltage alarm, open collector.

Features

- Conformally coating, tropic.
- Under voltage logic alarm.
- Accessible on front panel:
 - Output voltage adjustment.
 - Output voltage measurement.
 - Output OK status green LED.

EMC

- EN61000-6-3, Emission.
- EN61000-6-2, Immunity.
- EN/IEC61000-4-4, 4kV.
- EN/IEC61000-4-5 level 2&3.

Input ratings

Nominal inputs	Input range	Code
24 Vd.c.	18 to 32V	24
48 Vd.c.	38 to 60V	48
110, 127 Vd.c.	88 to 150V	110
220, 250 Vd.c.	175 to 300V	220
440Vd.c.	350 to 550V	440

Other input ranges on demand.

T-input for Mobile application ranges

Code	Continuous range	Uin 0.1s- S2
24T	16.8 - 30Vd.c.	14.4 - 33.6Vd.c.
36T	25.2 - 45Vd.c.	21.6 - 50.4Vd.c.
48T	33.6 - 60Vd.c.	28.8 - 67.2Vd.c.
72T	50.4 - 90Vd.c.	43.2 - 100.8Vd.c.
110T	77 - 137.5Vd.c.	66 - 154Vd.c.

The total output power can be derated on a T-range compared to the above output rating table.

Output ratings and typecode

Output			Input					Case
Voltage	Current	Power	18 - 32V	38 - 60V	88 - 150V	175 - 300V	350 - 550V	
15V	14.0A	210W	PSC240 24/15	PSC240 48/15	PSC240 110/15	PSC240 220/15	--	12TE
24V	10.0A	240W	PSC240 24/24	PSC240 48/24	PSC240 110/24	PSC240 220/24	PSC240 440/24	12TE
48V	5.00A	240W	PSC240 24/48	PSC240 48/48	PSC240 110/48	PSC240 220/48	PSC240 440/48	12TE
110V	2.18A	240W	PSC240 24/110	PSC240 48/110	PSC240 110/110	PSC240 110/110	PSC240 440/110	12TE

Other input and outputs combination on demand.

For compatible AC input models, please ask for PSC-AC series datasheet.

How to read our product code:

Example **PSC240 48/24**

PSC240 = Family code

48 = input voltage code

24 = Output voltage 24V

Features

Under voltage logic alarm

On DC-inputs a built in logic alarm changes to alarm state if the converter output voltage drops 10% below nominal output. The DC OK LED is also controlled by the alarm circuit. The alarm has an open collector configuration. A voltage < 1V is normal operating condition. In alarm state the output can drive max 20mA 60V. The logic alarm works if a voltage is applied through a resistor on the collector output max voltage 60V. For relay output, see option B

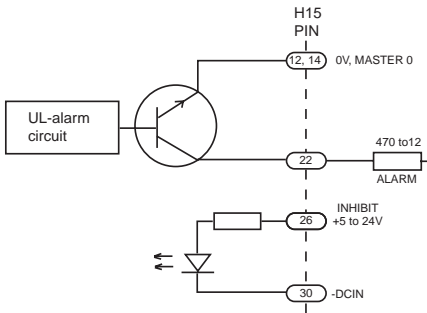

Figure 5. Open collector alarm and inhibit input.

Inhibit – power down signal

To stop the converter, an external voltage (5 to 24 V) can be put between pin 26 and input zero (pin 30), see page 3. Do not use the output voltage to supply the inhibit.

Reverse input voltage protection

Is provided by a parallel diode on the input. This diode is only intended to blow an external input fuse. See option K for more possibilities.

Inrush current limit

A NTC resistor is provided on models with input code 220 and 440.

Adjustment & measurement

Output voltage adjustment potentiometer and output voltage measurement points are accessible from the front panel.

Conformal coating

The PSC-series is conformally coated to withstand non-condensing tropical environment Rh 95%.

Optional Features

Overvoltage protection OVP-A

The output voltage is limited to 15% over nominal output voltage. A SCR short-circuits the output. It is reset by switching off the input or by an Inhibit signal. The OVP circuit is a standard feature on 5V outputs, which triggers at 6.2V

Undervoltage alarm with relay -B

The standard under voltage logic alarm circuit output is replaced by a relay fault signalling output.

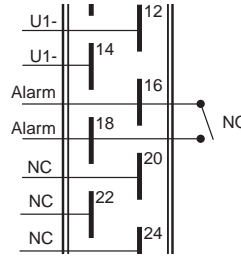

The relay logic is NO (Normally Open) in alarm state. (Alarm state = no input or low output.) The relay rating is 30V 0.5A (a.c. & d.c.) Connect according to figure between Pin 16 and 18 on the H15 connector.

On PSC240 440 input code models the user can select NO or NC function. Then pin 20 is also used.

Built in series diode -C

A series diode on the output, which is mounted inside the case. Use this option when output is connected in parallel with other power supplies to achieve redundancy.

Remote sense -S

The voltage sensing can be put at the load to compensate for voltage drop.

Inrush current limit with NTC

Reduce the inrush current during start up. The input voltage range might be affected. This feature or option is not recommended for stand-by operation (One supplies the load and the other is used as an idling back-up). The stand-by unit might not be able to supply enough current until the NTC warms up.

Input diode for reverse voltage protection - K

Parallel diode reverse protection is a standard feature.

K1. Reverse protection with a series diode on the input. The input voltage range is affected with 1V higher start/stop voltage. On 24 and 48 this option derates the output power by the increased heat losses produced by such diode. Contact factory for details.

K2. Addition of a glass fuse. Can not be used on higher inputs than 180Vd.c.

2.5 kVa.c. isolation Input/case -E!

On 24 and 48 inputs. The emission level increase to level A.

Pin-out

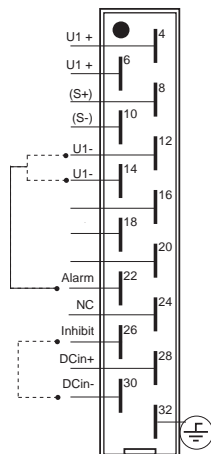

Figure 1. Pin-out single output with Connector DIN41612, H15.

2.5 kVa.c. isolation Output/case -E2
The emission level increase to level A.

Euro panel -L, 12TE see figure 7

Wall mounting panels -N, see figure 8 & 9
Includes H15 connector holder. The female connector has to be added. To mount on a DIN TS-35 rail, we can supply an optional DIN rail clips

Connector Options

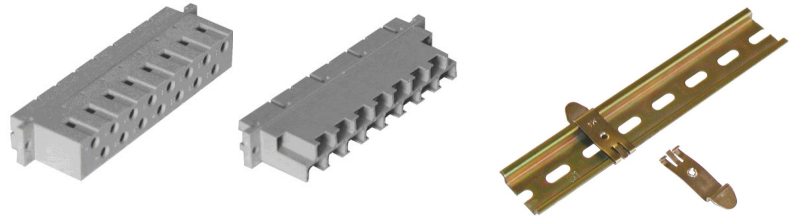

H15 female Screw Connector H15-S

FastOn 6.3mm Connector H15-T

DIN-rail Clips

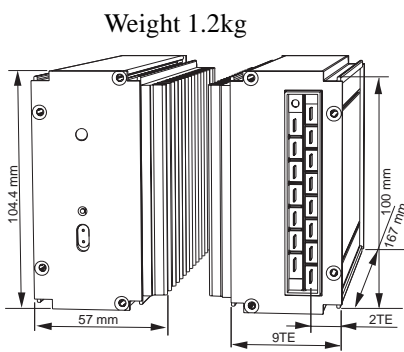

Figure 6. Front and connector side of PSC240

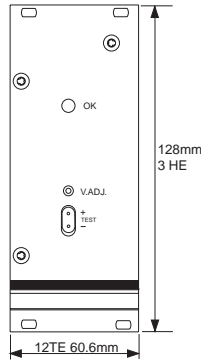

Figure 7. 12TE Front panel 3HE option L

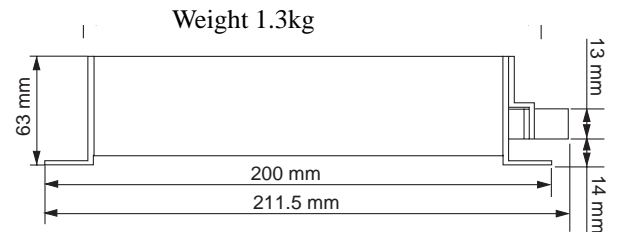

Figure 8. Side view on wall mounting option N

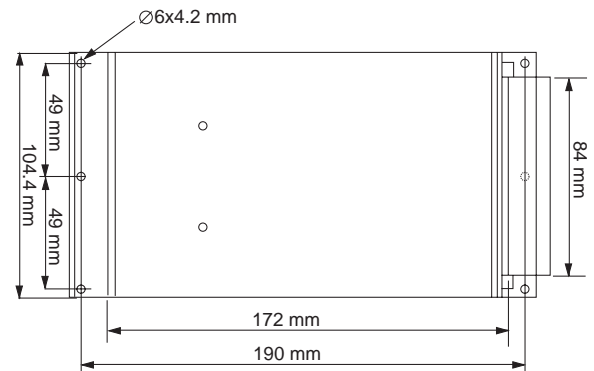

Figure 9. Top view on wall mounting option N

The PSC-family are built in a tubular aluminium extrusion, with high thermal conductance which also work as a good EMC shield. The mechanical design permits use in vehicles and heavy industrial environments. The IP class is IP30. On special demand up to IP54 can be supplied using special connectors.

Vibration and shock resistance is high in standard DIN431605: 6g 10ms (5000 times in 3 directions) Higher as 15g 50ms or 30g 10ms can also be provided on demand.

General data DC/DC Converters

Design topology	Push-Pull
Switching frequency	50 kHz
Emission / immunity	See page 7
Safety EN/IEC60950	Class I
Max accepted input ripple 50 - 400Hz	1% of nom. Voltage
Power consumption at no load	3 to 5W
Reverse input voltage protection	Parallel diode
Inrush current limit with	
Input Code 24, 48	No
Input Code 110	Optional NTC
Input Code 220, 440	Yes with NTC
Insulation	See page 7

Output data

Source regulation	0.2%
Load regulation (0-100% load) master	0.2%
Transient recovery time for a load step of 10% to 100% voltage deviation	<2ms 3%
Output ripple (50kHz) 2 Vp-p ²	Typ. 10mV
Input ripple attenuation on output 50 to 400Hz	150:1
Emission / Immunity	See page 4
Temperature coefficient	0.02% /°C
Min output adjustment range adjustable with a 15 turn potentiometer	90% to 110%
Current limit, rectangular.	105%
Remote sense	Option S
Soft start	Yes
Isolation output / case	See page 4
Start-up time	1s
Hold-up time, contact factory	2-25ms
Efficiency ³	80 - 91%
Operating temperature range at 100% load. Conduction cooling	-25 to +70°C
Storage temperature range	-40 to +85°C

- Output ripple might increase when IEC/EN61000-4-3 10V/m test is applied to max 0.5% V_{RMS}
- Lowest efficiency measured within the whole input voltage range at 100% load.

Safety standard IEC60950

Isolation testable levels	Input code	
	24, 48	110, 220 440
Input / output:	2kVd.c.	2.5kVa.c. / 4kVd.c.
Input / Case	2kVd.c.	2.5kVa.c. / 4kVd.c.
Output / Case all outputs	2kVd.c.	2kVd.c.
Master output / Auxiliary outputs	2kVd.c.	2kVd.c.
Alarm / Input	2kVd.c.	2.5kVa.c. / 4kVd.c.
Isolation, not testable level Safety Isolation		
Transformer isolation In/Out:	2kVd.c.	4 kVa.c./8mm

We use the product standard Low voltage power supplies, DC outputs EN/IEC61204-3 and the generic EMC standards:
 EN/IEC61000-6-2 (Immunity)
 EN/IEC61000-6-3 (Emission)

EMC

EMC-standards	EMC-performance		Remarks
Emission standards	Input	Output	
EN55011/EN55022 (0.15-30MHz)	Level B	Level B	
EN55011/EN55022 (30-1000MHz)	Level B		Enclosure test
Immunity standards	IEC/EN61000-6-2		
EN/IEC61000-4-2	8 kV/15 kV		Contact / air, Enclosure test
EN/IEC61000-4-3	10 V/m AM-Modulated		Output ripple can increase to 0.5% of Vout Enclosure test
EN/IEC61000-4-4	4 kV	4 kV	
EN/IEC61000-4-5, Input code 24, 48	0.5kV / 1 kV	0.5kV / 1 kV	Line-line 2Ω / Line-case 12Ω
EN/IEC61000-4-5, Input code 110 ¹ , 220 ¹ , 440 ¹	1kV / 2 kV	0.5kV / 1 kV	
EN50155 Figure 4, 1.8kV 1.5/50μs	Yes		Line-line 100 Ω
EN/IEC61000-4-6	10 V _{RMS}	10 V _{RMS}	AM-Modulated
EN/IEC61000-4-8	Not sensitive		Enclosure test
EN/IEC61000-4-10	Not sensitive		Enclosure test

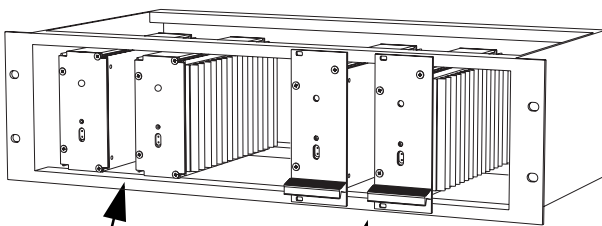

PSC mounted in a 19" Sub-rack. Standard unit.

PSC mounted in a 19" Sub-rack with L panel (Optional)

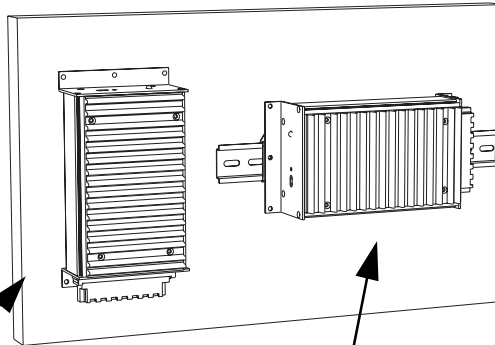

PSC wall mounted. Using PSC wall mounting kit including connector holder. The female H15 connector is optional. See page 5 for the selection

PSC DIN-rail mounted. Using PSC wall mounting kit with H15 connector, connector holder and DIN-rail clips (Optional).

Contact

For updates on this datasheet we refer to www.polyamp.com
 Specifications subject to change without notice.



Switch Craft S.A.
 Ruel bel Air 63
 CH-2300 La Chaux-de-Fonds Switzerland
 Telephone: +41 32 96 78800
 Telefax: +41 32 96 78809
 E-mail: info@polyamp.se

Distributor