

# DDPC Diode Driver Data Sheet

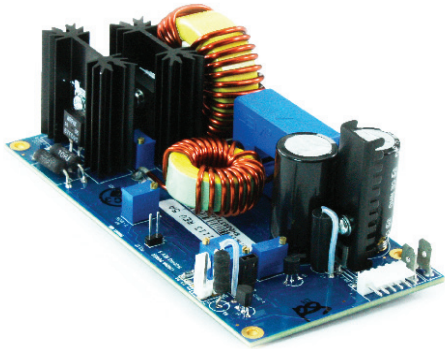

The DDPC series laser diode drivers offer the laser designer a compact low cost power supply for a variety of medical and industrial applications. In order to take full advantage of this unique product, care must be taken during the design process to ensure long term reliability. This data sheet includes answers to many commonly asked questions about the various configurations available and includes critical cooling and electrical information.

## Specifications

Maximum Output Power: 300 watts: See Chart Page 2

### Performance

Current Ripple: 0.2% at maximum output current  
Regulation: 0.5% at maximum output current  
Current Overshoot: < 1% of maximum output current  
Power Limit: Limited to Maximum power with Fold Back Circuit  
Rise/Fall Time: 3-20 $\mu$ s. depending upon output voltage

### Interface

Inhibit/Enable: 5V to 15V to enable output  
Current Program: 0 to 10V = 0 to full current  
Current Monitor: 0 to 10V = 0 to full current  
Voltage Monitor: 0 to 10V = 0 to full voltage<sup>1</sup>

### Protection

Power supply Protection: Reverse Input voltage, input overvoltage, over temp  
Laser Diode Protection: Control rise/fall times, no overshoot

### Dimensions

DDPC < 110watts: 68.75mm x 150mm x 45mm high  
DDPC > 110watts: 68.75mm x 150mm x 73.1mm high  
Operating Temp: 0 to 40°C, 90% RH non condensing  
Cooling<sup>2</sup>: See page 3 for fan size and mounting instructions

1. If maximum compliance voltage is less than 10V, Vout Monitor will read output voltage directly. If maximum compliance voltage is greater than 10V, then Vout Monitor will be scaled such that 0-10V = 0-Voutmax.
2. Proper cooling is required for reliable operation. See page 3 for correct fan placement and other cooling recommendations.

© 2012 Lumina Power, Inc. All Rights Reserved 3/15/12



# DDPC Diode Driver Data Sheet

## Maximum Output Ratings

The DDPC laser diode drivers are available in two power levels. Models to ~ 100watts (50amps) can be operated from 12 or 15 volts while power levels up to 300 watts (50-70 amps) require 24VDC input. The table to the right details typical input voltages and currents when the units are run at maximum output current for their particular power rating. The DDPC power supplies can be ordered with any output voltage and current as long as you do not exceed the maximum parameters listed.

OutputV @ Max current	Output Power	Input Current	Efficiency
24VDC input			
2V @ 50A	100 watts	7.0A	60%
4V @ 40A	160 watts	9.0A	74%
6V @ 40A	240 watts	12.6A	79%
2V @ 70A	140 watts	9.0A	74%
10V @ 30A	300 watts	14.7A	85%
16V @ 19A	304 watts	14.1A	90%
12VDC/15VDC input			
2.38V @ 50A	119 watts	11.6A/15Vin	72%
2.38V @ 50A	119 watts	14.9A/12Vin	72%

**Part Number Example:** DDPC-10-6-12 = 10amps, 6 volts output, 12VDC input  
Maximum compliance voltage for output currents > 50amps is 2 volts.

## Interface Description

The DDPC interface is a simplified version of the LDD series controls utilizing the same analog 10 volt programming. The connector is a 6 pin right angle board mounted Molex #22-05-3061. There are several options for the mating connector (not included) but a suitable part number is the 22-01-2067. Note Vmon. (pin 2) scale for various output voltages.

Pin	Function	Description	Impedance
1	Enable	5 to 15V=Enable Output, Default OFF	10K
2	V monitor	1 to 1 for $V_{out} \leq 10V$ 0 to 10V = 0 to full scale for $V > 10V$	1K
3	Pulse	TTL High = ON, Default = High	10K
4	I prog	0 to 10V = 0 to Full scale	10K
5	GND		N/A
6	I mon	0 to 10V = 0 to Full Scale	1K

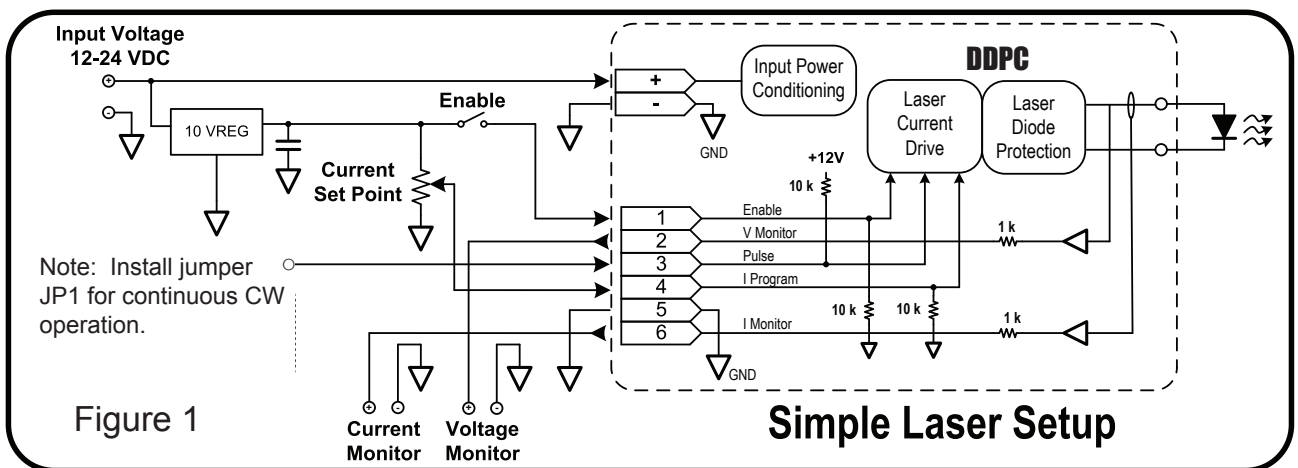

# DDPC Diode Driver Data Sheet

## Connectors

- 1 Input Connector:** .25" male Quick Connects.  
**Note:** Input current cannot exceed 15 amps.
- 2 Interface Connector:** Molex # 22-05-3061.
- 3 Fan Output:** J1 (Molex # 26-60-4020 ) output is equal to the input voltage for 12 or 24 volts input. For 15 VDC input J1 = 12 V.
- 4 Output Connectors:** 6 x 32 Screws. See outline drawing below for location.

Figure 2

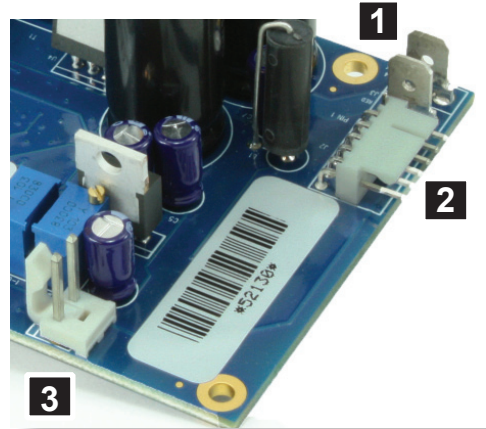

## Cooling Requirements

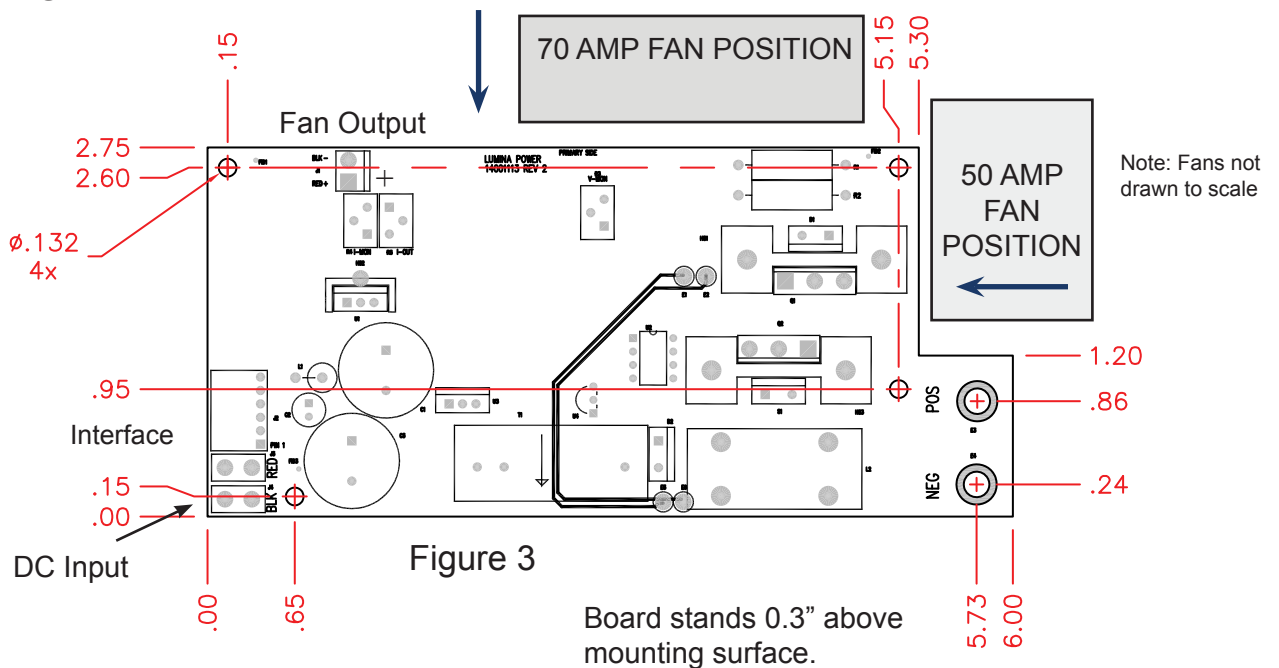

### Recommended Fan:

- ≤ 50 amps:** ≥10cfm, 60mm x 60mm fan
- 50 to 70amps:** 37cfm, 60mm x 60mm fan

Proper cooling of the DDPC board is critical to the operation and reliability of the product. The diagram above shows the fan positions and required airflow for the various output currents. The fan must be positioned as shown in diagram above. Mount fan .25" from board for proper cooling. **Note:** Failure to properly cool the board using the correct size and position of the fans may result in thermal shutdown and potential catastrophic damage to the power supply. Damage to the board from inadequate cooling is not covered under warranty.

# DDPC Diode Driver Data Sheet

## Pulsed Operation Figure 4

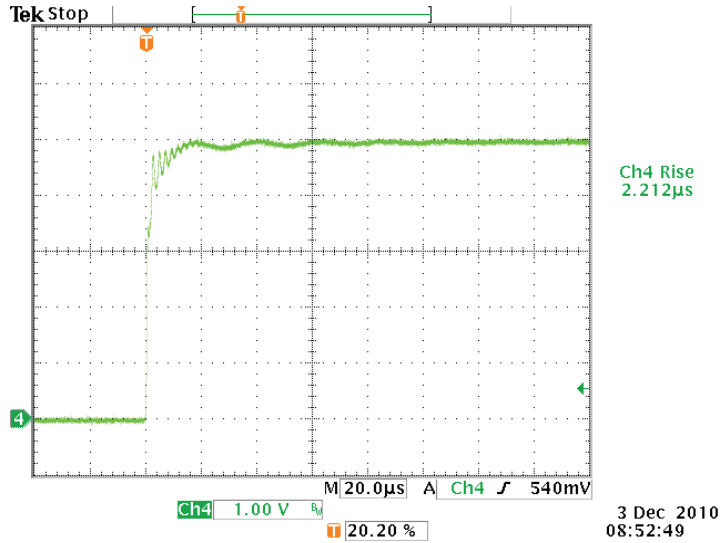

The DDPC supplies are primarily designed for CW operation but have a very short rise/fall time and are easily pulsed using pulse pin (#3) on the interface connector. Figure 4 (left) is a scope trace of a 50 amp 2 volt pulse with a rise/fall time of 2.2µs. The chart below shows typical compliance voltage/rise time values.

Compliance voltage	Rise/fall time
2 volts	3µs.
4 volts	5µs.
6 volts	7µs.
8 volts	10µs.
10 volts	12µs.
12 volts	15µs.
14 volts	17µs.
15 volts	20µs.

## Start-up Procedures

If you are using this product for the first time please read and follow the following procedures:

1. Unpack module and position the device on a flat surface with the heat sinks up. The DDPC module will not cool properly when mounted upside down (heatsinks down). Locate proper size fan as outlined on page 3. (Consult customer service for proper vertical mounting and cooling).
2. To protect your laser diode from damage it is recommended that you apply a dummy load to the output of the DDPC module during tests. A standard "fast recovery" diode or series string of these diodes that approximately matches the voltage drop of your laser diode should be used for testing.
3. Connect your current monitoring device to the current monitor output pin 6 on the interface connector. A digital voltage meter set to 0 to 10V for CW operation or a scope for pulsed operation. Connect a 0 to 10V program voltage to the current program input pin 4. Optional: you can monitor compliance voltage at the voltage monitor output pin 2. Install jumper JPI for pulsed operation or a TTL pulse source for QCW.
4. Apply DC input voltage, apply a signal to enable pin 1 and adjust current program voltage to desired output current. Monitor output current with monitoring device. See interface description, page 2 for input and output voltages.
5. For pulsed operation connect pulse pin 3 to a pulse signal.

Note: Grounding the negative output of the module may cause ground loops and excessive noise.

© 2012 Lumina Power, Inc. All Rights Reserved 3/15/12

