

# DDPC Diode Driver Application Notes



The DDPC series laser diode drivers offer the laser designer a compact low cost power supply for a variety of medical and industrial applications. In order to take full advantage of this unique product, care must be taken during the design process to ensure long term reliability. These application notes include answers to many commonly asked questions about the various configurations available and includes critical cooling and electrical information.

## Specifications

Maximum Output Current:

See Chart Page 2

### Performance

Current Ripple:

0.5% at maximum output current

Regulation:

0.5% at maximum output current

Current Overshoot:

< 1% of maximum output current

Power Limit:

Limited to Maximum power with Fold Back Circuit

Rise/Fall Time:

150usec. typical, Note:2 to 10 $\mu$ s rise times available

### Interface

Inhibit/Enable:

5V to 15V to enable output

Current Program:

0 to 10V = 0 to full current

Current Monitor:

0 to 10V = 0 to full current

Voltage Monitor:

0 to 10V = 0 to full voltage<sup>1</sup>

### Protection

Power supply Protection:

Reverse Input voltage, input overvoltage, over temp

Laser Diode Protection:

Control rise/fall times, no overshoot

### Dimensions

DDPC  $\leq$  50 amp:

2.75 inches X 6.0 inches (board height 1.5")

DDPC > 50 amp:

2.75 inches X 6.0 inches (board height 2.625")

Operating Temp:

0 to 40°C (Consult factory for cooling requirements)

Cooling<sup>2</sup>:

$\leq$  50 amp Models require 10CFM or greater

> 50 amp Models require 37CFM or greater

1. If maximum compliance voltage is less than 10V, Vout Monitor will read output voltage directly. If maximum compliance voltage is greater than 10V, then Vout Monitor will be scaled such that 0-10V = 0-Voutmax.

2. Proper cooling is required for reliable operation. See page 3 for correct fan placement and other cooling recommendations.

# DDPC Diode Driver Application Notes

## Maximum Output Ratings

The DDPC laser diode drivers are available in two power levels. Models to 100 watts can be operated from 12 or 15 volts while power levels up to 300 watts require 24VDC input. The table to the right details typical input voltages and currents when the units are run at maximum output current for their particular power rating. The DDPC power supplies can be ordered with any output voltage and current as long as you do not exceed the maximum parameters listed.

OutputV @ Max current	Output Power	Input Current	Efficiency
24VDC input			
2V @ 50A	100 watts	7.0A	60%
4V @ 40A	160 watts	9.0A	74%
6V @ 40A	240 watts	12.6A	79%
4V @ 70A	280 watts	16.0A	74%
10V @ 30A	300 watts	14.7A	85%
16V @ 19A	304 watts	14.1A	90%
12VDC/15VDC input			
2.38V @ 50A	119 watts	11.6A/15Vin	72%
2.38V @ 50A	119 watts	14.9A/12Vin	72%

**Part Number Example:** DDPC-10-6-12 = 10amps, 6 volts output, 12VDC input

## Interface Description

The DDPC interface is a simplified version of the LDD series controls utilizing the same analog 10 volt programming. The connector is a 6 pin right angle board mounted Molex #22-05-3061. There are several options for the mating connector (not included) but a suitable part number is the 22-01-2067. Note Vmon. (pin 2) scale for various output voltages.

Pin	Function	Description	Impedance
1	Enable	5 to 15V=Enable Output, Default OFF	10K
2	V monitor	1 to 1 for $V_{out} \leq 10V$ 0 to 10V = 0 to full scale for $V > 10V$	1K
3	Pulse	TTL High = ON, Default = High	10K
4	I prog	0 to 10V = 0 to Full scale	10K
5	GND		N/A
6	I mon	0 to 10V = 0 to Full Scale	1K

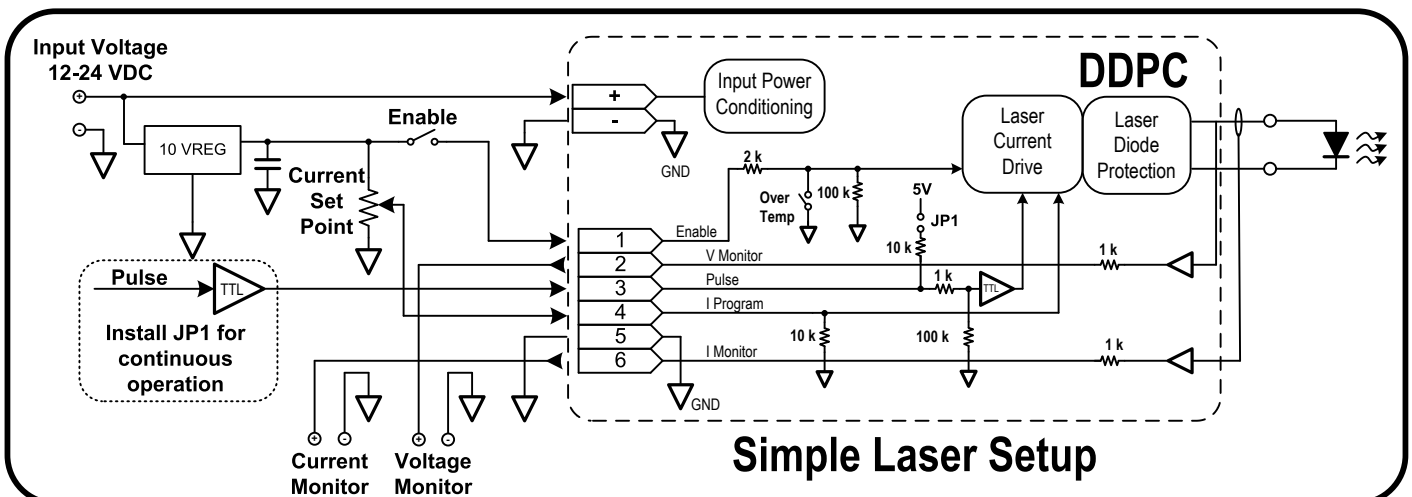

## DDPC Diode Driver Application Notes

### Connectors

- 1** **Input Connector:** .25" male Quick Connects.  
**Note:** Input current cannot exceed 15 amps.
- 2** **Interface Connector:** Molex # 22-05-3061.
- 3** **Fan Output:** J1 output is equal to the input voltage of 12 or 24 volts. For 15 VDC input J1 = 12 V.
- 4** **Output Connectors:** 6 x 32 Screws. See outline drawing below for location.

Figure 2

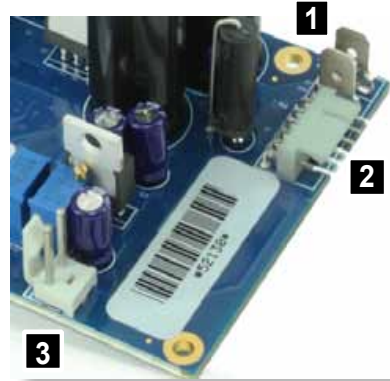

### Cooling Requirements

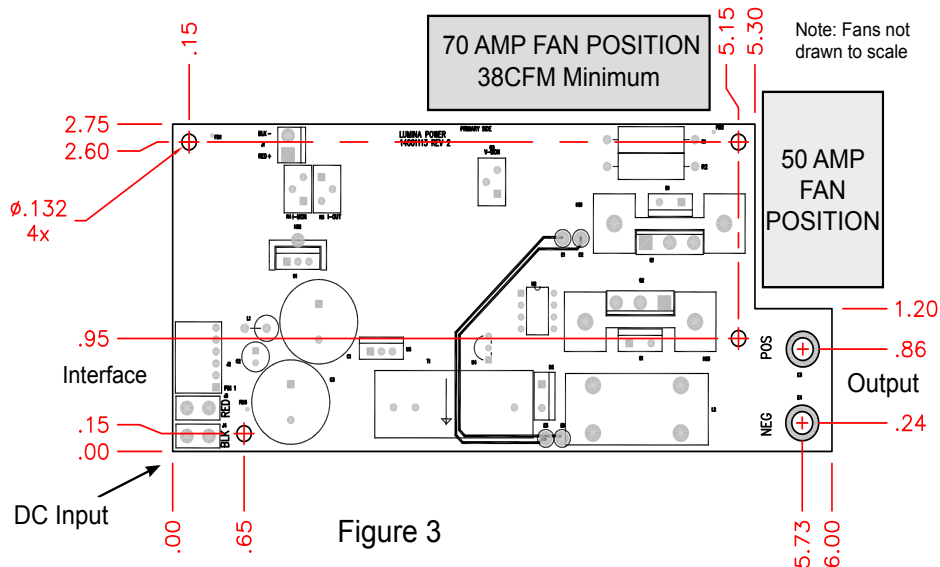

Figure 3

#### Recommended Fan:

**≤ 50 amps:** 10cfm, 40mm x 40mm, Delta: #EFB0412VHD (12V) or EFB0424VHD (24V) or equiv.

**50 to 70amps:** 37cfm, 60mm x 60mm Sanyo Denki: # 109R0624J402 or equiv.

Proper cooling of the DDPC board is critical to the operation and reliability of the product. The diagram above shows the fan positions and required airflow for the various output currents. The fan must be positioned as close to the board as possible to properly cool the heatsinks. Note: Failure to properly cool the board using the correct size and position of the fans may result in thermal shutdown and potential catastrophic damage to the power supply. Damage to the board from inadequate cooling is not covered under warranty.

# DDPC Diode Driver Application Notes

## Pulsed Operation

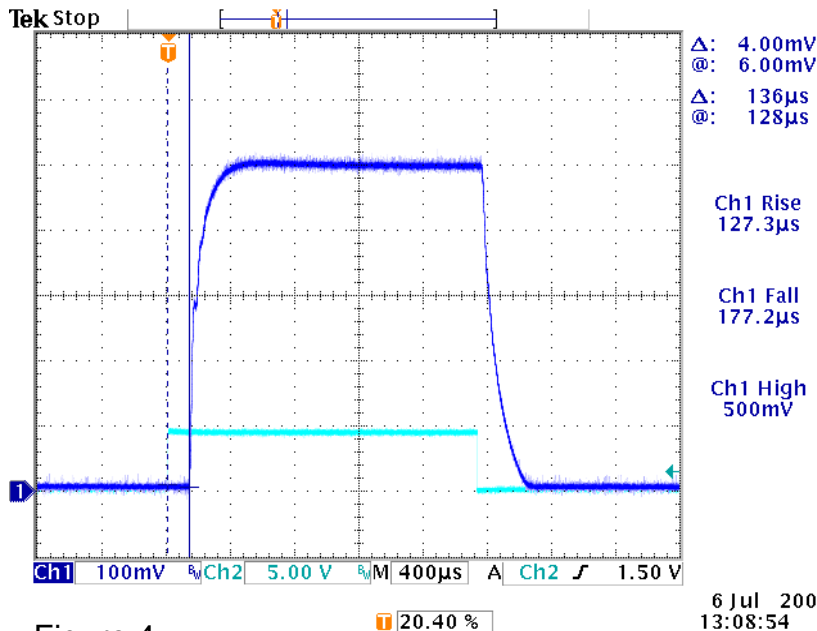

Figure 4

The DDPC supplies are primarily designed for CW operation but have a very short rise/fall time and are easily pulsed using the pulse pin (#3) on the interface connector. Figure 4 (left) is a scope trace of a 50 amp pulse with a rise time of 127.3 μs. and a fall time of 177.2 μs.

Shorter rise/fall times can be specified with minimum times of 2 to 10 μs. possible depending upon output voltage and current requirements.

For pulsed applications from 70 amps to 250 amps we also offer the LDQPC series board level power supplies. Please consult your local representative for more information.